

Figure 13. - Final Drive

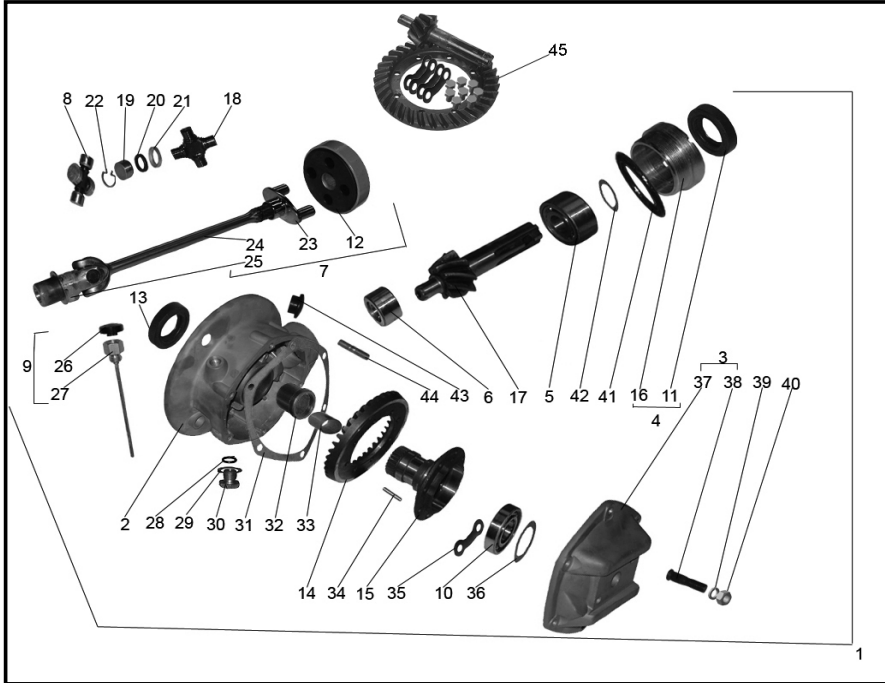

Figure 13. - Final Drive

Item	Part #	Description	Notes	Q-ty
1	IMZ-8.103-05001-01	Final drive assy	Installed to July of 05	1
1	IMZ-8.103-05001-02	Final drive assy	Installed since July 05. Up-graded final drive	1
2	IMZ-8.103-05101-10	Final drive case		1
2	IMZ-8.103-05101-20	Final drive case	Installed since July 05. For Rubena seal	1
3	IMZ-8.103-05020	Case cover	Installed before July 05. With special bolt IMZ-8.101-05131 or IMZ-8.103-05131	1
3	IMZ-8.103-05020-10	Case cover	Installed since July 05 - See item #46 for fastening hardware	1
4	IMZ-8.101-05023-12	Bearing nut, assy, final drive	Installed before July 05. Different seal diameter of bore	1
4	IMZ-8.103-05023	Bearing nut, assy, final drive	Installed since July 05	1
5	72052-1	Roller bearing		1
6	72052-2	Double raw ball bearing		1
7	IMZ-8.103-05040	Drive shaft assy	Installed before July 05 - Flex coupling (item#12) not included	1
7	IMZ-8.103-05040-10	Drive shaft assy	Installed since July 05. - Flex coupling (item#12) not included	1
7	IMZ-8.1037-05056	Drive shaft assy	Installed from 2007 - Flex coupling (item#12) not included	1
8	ИМЗ-8.101-05017	Flexible U-joint coupling	Assembly	1
9	IMZ-8.103-05032	Dipstick and breather		1
10	207	Ball bearing	Russian - May use new bearing below	1
10	6207-2rs1/c3	Ball bearing	New bearing from 2007	1
11	IMZ-8.103-04015-01	Seal assy	Installed before July 05. Russian seal. Different outer & inner diameters	1
11	NAK TC 03103	Seal assy	New seal - Installed since July 05.	1
12	72-05013	Flexible U-joint coupling		1
13	IMZ-8.101-05039	Gear case seal	Installed before July 05. Different diameter of bore	1
13	IMZ-8.103-05039	Gear case seal	Installed since July 05	1
13	NAK TC 02861	Gear case seal	New seal good from July of 2005	1

Figure 13. - Final Drive

Item	Part #	Description	Notes	Q-ty
14	72-05227	Final drive driven gear	See fig. 13, #45. It is recommended that parts 72-05202-01 & 72-05227 are ordered in a set, as they are factory-bedded for noiseless operation	1
15	IMZ-8.103-05229	Final drive driven gear hub		1
16	IMZ-8.101-05223 -20	Bearing nut	Installed before July 05. Different seal diameter of bore	1
16	IMZ-8.103-05223	Bearing nut	Installed since July 05	1
17	72-05202-01	Final drive driving gear	See fig. 13, #45. It is recommended that parts 72-05202-01 & 72-05227 are ordered in a set, as they are factory-bedded for noiseless operation	1
18	IMZ-8.103-05311	Drive shaft cross	See fig. 13, #8. These are sold as an assembly	1
19	72053-2	Needle bearing	See fig. 13, #8. These are sold as an assembly	4
20		U-joint sealing ring	See fig. 13, #8. These are sold as an assembly	4
21	72-05313	U-joint sealing ring band	See fig. 13, #8. These are sold as an assembly	4
22	367309	U-joint lock ring B19	Also included in assembly, #8	4
23	IMZ-8.103-05307	Flexible U-joint plate	Installed before July 05. Different length of splines	1
23	IMZ-8.103-05307-10	Flexible U-joint plate	Installed since July 05	1
24	IMZ-8.103-05301	Drive shaft	Installed before July 05. Different length of splines	1
24	IMZ-8.103-05301-10	Drive shaft	Installed since July 05	1
25	IMZ-8.101-05049	Drive shaft fork assy	Installed before July 05. Different seal diameter of bore	1
25	IMZ-8.101-05049-10	Drive shaft fork assy	Installed since July 05	1
26	IMZ-8.103-04380	Breather plug		1
27	IMZ-8.103-05034	Dipstick assy		1
28	IMZ-8.101-01135	Ring		1
29	11407	Special washer 14		1
30	IMZ-8.103-01080	Drain plug		1
31	72-05107	Gear case gasket		1
32	IMZ-8.101-05104	Gear case bushing		1
33	IMZ-8.103-05246	Distance bushing		1
34	3x15,8 A5	Needle roller		45

Figure 13. - Final Drive

Item	Part #	Description	Notes	Q-ty
35	6205232	Lock plate		4
36	7205241	Shim 0,08...0,07 mm		1
36	7205242	Shim 0,18...0,16 mm		1
36	6205243	Shim 0,4...0,36 mm		1
37	IMZ-8.103-05121	Gear case cover	See item #46 for fastening hardware.	1
38	IMZ-8.101-05131	Special washer M10x1,25	Installed before July 05. Different thread dimension	2
38	IMZ-8.103-05131	Special washer M10x1,25-6g	Installed since July 05	2
39	252156-P2	Washer 10L		2
40	250513 P27C	Nut M10x1	Installed before July 05. Different thread dimension	2
40	367200-P27C	Nut M10x1,25-6H,	Installed since July 05	2
41	7205224-01	Bearing nut gasket		1
42	6205319	Shim0,18...0,16 mm		1
42	7205320	Shim 0,4... 0,36 mm		1
43	62-01254	Stopper		1
44	365632-P27	Screw M8x1x22		6
45	IMZ-8.101-05047	Bevel gears set		1
46	250513-P29	Nut M10x1	Not Pictured - Fastening nut for case cover used thru 2006	6
46	E00871	Self locking M10x1,25	Not Pictured - Fastening nut for case cover used from 2007	6